

**Programmes After Market Services (PAMS)
Technical Documentation
NME-2A Series Transceivers**

Chapter 5

Handset HSE - 6XA

AMENDMENT RECORD SHEET

Amendment Number	Date	Inserted By	Comments
	08/97		Original

CHAPTER 5 – HANDSET HSE - 6XA

CONTENTS

	Page No
Introduction	5 – 5
Technical Summary	5 – 5
Modes of Operation	5 – 5
External Signals and Connections	5 – 5
Display Specifications	5 – 6
Functional Description	5 – 7
Functional Blocks	5 – 7
Circuit Description	5 – 9
General	5 – 9
Construction	5 – 9
Handset Module	5 – 9
Microphone Amplifier	5 – 9
Earphone Amplifier	5 – 10
CPU with Peripherals	5 – 10
HOOK Indicator	5 – 10
M2BUS Electronics	5 – 10
LCD Display	5 – 10
Display Controller/Driver	5 – 10
Keyboard Matrix	5 – 11
Illumination	5 – 11
Voltage Supply	5 – 11
Power on/off Logic	5 – 11
Oscillators	5 – 12
Assembly Parts	5 – 14
Parts List of EH9 v. 3.4	5 – 15
Parts List of EH9 v. 4.1	5 – 20

List of Figures

	Page No
Figure 1. Handset connector	5 – 6
Figure 2. Block Diagram – HSE-6XA	5 – 13
Figure 3. Exploded View HSE-6XA	5 – 14
Schematic Diagrams:	
Circuit Diagram EH9 Module (Version: 0.8 Edit 48)	5/A3 – 1
Component Layout Diagrams EH9 Module Side 1	5/A3 – 2
Component Layout Diagrams EH9 Module Side 2	5/A3 – 3

Introduction

The HSE-6XA Handset has two main functions: to form an electro-acoustic interface between the user and the transceiver unit and to provide means for controlling the transceiver unit and other accessories.

The HSE-6XA is divided into two parts: the EH9 electronics module and the MHSE6XA mechanics. The EH9 module consists of an 8-bit microprocessor with internal memory, a 2x8 character display (+ 2 seven-segment) with one driver IC, keyboard, earphone, microphone, loudspeaker and corresponding amplifiers.

The mechanics consist of the A-cover (front), B-cover (rear), keyboard rubber mat, coiled cord, display frame and a number of smaller parts.

The HSE-6XA is designed for single-handset systems and for mobile use only, so it has no audio switches, and is not provided with functions for a power-safe or sleep mode.

Technical Summary

Modes of Operation

The HSE-6XA has only one mode of operation, used when the handset is operating as a combined handset and control unit. There is no need for a local mode because all testing can be done by means of M2BUS-messages.

External Signals and Connections

The HSE-6XA has an 8-pin connector for connection to the junction box, system cable and transceiver via coiled cord.

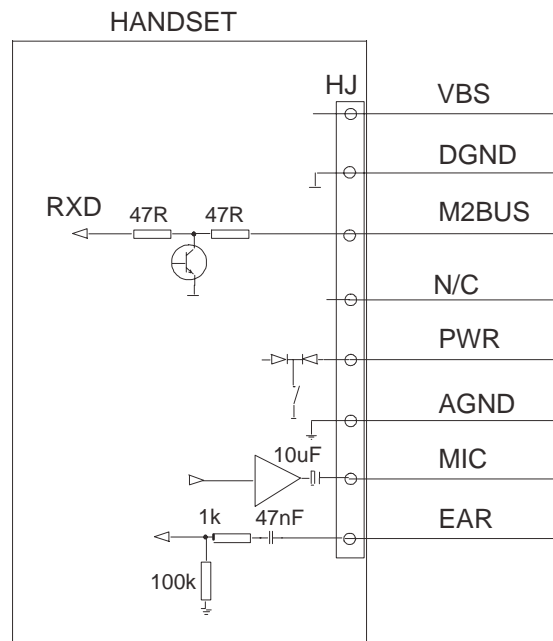

Figure 1. Handset connector

Signal names and basic interface connections:

Pin	Name	Level	Comments
1	VBS	typ. 13.2 V	
		min. 10.0 V	
		max. 17.0 V	
2	DGND		Digital ground
3	MBUS	Input: "0" < 0.9 V	Input levels at processor
		"1" > 1.9 V	input/RxD
		Output: "0" < 0.5 V	Max allowed capacitance 2 nF
4		No connection	
5	POWER		Series diode dropout 0.7 V
6	AGND		Analog ground
7	MIC	max. 2 V _{rms}	No DC connection
8	EAR	max. 1.2 V _{rms}	DC 0.0 V

Display Specifications

The HSE-6XA comprises a 16 character (5x2) dot matrix and two and a half seven segment indexes.

The HSE-6XA comprises a 2x8 (5x7) dot matrix display for 2 seven-segment characters, a signal strength indicator (left bar) and a number of fixed indicators over and under the character lines.

The yellow-green supertwist liquid crystal display is connected to the pcb by means of elastomer connectors. The display is illuminated with green LEDs from both sides.

Technical specifications for the display include:

Display type	Yellow-green supertwist lcd, transfective
Illumination colour	Yellow-green LED
Driving mode	MUX 1:16, 1/5-bias
Driving voltage	7.5 V at +25°C
Temp. compensation	30 mV/°C
Lens thickness	1.1 mm
Display driver	NEC μ PD7228AG
Storage temperature	-30...+85°C
Oper. temperature	-25...+70°C
Humidity	typ. 50% RH max. 90% RH
Response times	$t_{(rise)} < 100 \text{ ms (+25°C)} < 1500 \text{ ms (-25°C)}$ $t_{(fall)} < 100 \text{ ms (+25°C)} < 1500 \text{ ms (-25°C)}$

Functional Description

Functional Blocks

HSE-6XA Handset consists of the following functional blocks:

- Audio circuit
- Microprocessor
- Keyboard matrix
- Keyboard illumination
- Display controller/driver
- Voltage converter
- LCD display
- Display illumination

The Audio circuit consists of the earphone and the microphone and corresponding amplifiers.

The Microprocessor is a single chip version with internal ROM and RAM. The microprocessor controls all other blocks.

The Keyboard matrix is connected directly to microprocessor inputs and outputs.

Keyboard illumination is accomplished with LEDs and is switched on, off or dimmed by the microprocessor.

The Display controller/driver is connected to the microprocessor over a parallel data line, and contains a display data RAM and character generator ROM/RAM.

The Voltage converter converts the voltages of +5 V to -5 V and divides the voltage between +5 V and -5 V to five levels (V1...V5), which are connected to the display controller/driver.

The LCD display is connected to pcb and display drivers over two elastomer connectors.

The Display illumination is of the same type as the keyboard illumination.

Circuit Description

General

The user interface of the handset is of the menu type. Alphabetical characters can be used. A dot matrix display is provided.

Construction

The handset consists of two body halves with a PC board inserted in between. A coiled cord, a speaker, an earphone and a microphone are wired to the PC board.

Handset Module

The HSE-6XA handsets consist of the following functional blocks:

1. microphone amplifier
2. earphone amplifier
3. CPU with peripherals
4. Hook indicator
5. M2BUS electronics
6. LCD display
7. display controller/driver
8. keyboard matrix
9. illumination
10. voltage supply
11. power on/off logic
12. oscillators

Microphone Amplifier

The microphone is biased through the RC filter R135,C37,C65 and source resistor R49.

The frequency response of the microphone is filtered to obtain a suitable shape by low pass filters C10/R60 and R10/R11/C11/C12/C14/R8 and high pass filter R9/C13. The amplification is about 29 dB with a 1 kHz signal. The microphone amplifier is built around OPAMP N3 (pin 5,6,7).

Earphone Amplifier

The Earphone amplifier is of the differential type. Total amplification is about 10 dB. The reference voltage is 4.0 volts. The earphone amplifier is built around OPAMP N3 (pin 1,2,3 and pin 12,13,14)

CPU with Peripherals

Microprocessor D1 is a single chip version with internal ROM and RAM. It has 16 kbytes of ROM and 256 bytes of RAM. It controls the other blocks on the basis of information coming from the M2BUS. In addition, it reads the user inputs, and sends them to the M2BUS.

HOOK Indicator

On-hook/off-hook information is received from a reed relay, which is located on the PC board and controlled by a magnet in the handset cradle.

M2BUS Electronics

The MBUS is a serial data bus with which the handset sends messages to, and receives them from, the radio unit. Transistor V28 sends the outgoing messages (TXD). Incoming data comes to processor pin 11 (RXD). Net free state is controlled by software before message sending.

LCD Display

The display is a 16 symbol 5 x 7 dot matrix supertwist LCD with two 7-segment characters and a few indicators. The LCD is connected to the PCB by two elastomer connectors. The multiplexing ratio is 1:16.

Display Controller/Driver

The Display controller/driver is connected to the microprocessor by a parallel (4 bit) data line, and contains display data RAM and character generator ROM/RAM. All other characters are created by the processor ROM. There is reserved a memory location for one character in RAM, loaded by a M2BUS message.

Resistors R35, R42 and R88 comprise a resistor network from which the LCD driving voltages are received. The voltage between +5 V and - 5 V is divided to five levels which are applied to the display driver. R41 provides temperature compensation (about 10 mV/ °C).

Keyboard Matrix

Keyboard has a 3 x 8 line matrix. Four of the eight write lines are used in common with display driver data lines. A diode in each of these lines prevents any contention in data lines when two or more keys are depressed at the same time.

Illumination

The keyboard and the display are illuminated by LEDs. They can all be switched on or off. Furthermore the display LEDs have 3 dimmer levels. The on/off and dimmer function is controlled by the microprocessor. Variations in power supply voltage (10.8V to 15.6V) do not affect illumination as all LEDs are powered by constant current sources.

The keyboard is lit by 22 LEDs. There is one illumination LED for each button.

The display is lit by six LEDs V9...V14 (three in series). The LEDs are located on the PC board at the ends of the plastic display light conductor. The light conductor is beneath the display.

Voltage Supply

The handset receives the battery voltage of the radio unit (about 12 V). This voltage is fed to the LEDs and the voltage regulators. There is an eight volt regulator N3 for audio circuits and a five volt regulator, N4, for the logic.

The analog 8V supply is divided to 4.0 volt by resistors R3 and R4 and buffered by op.amp. N3 (pin 8,9,10) connected as a voltage follower to get the reference voltage for the audio amplifiers.

The negative five volt supply for the display driver is created by diode V29 and capacitors C17 and C24. The drive frequency is produced and buffered by inverter D3.

To avoid audio disturbances, ground potentials are separated between the analog and digital parts. AGND is the analog ground where the ground current is almost zero. DGND is the ground for the digital circuits and circuits which use more power, such as LEDs.

Power on/off Logic

The power on/off switch is located on the keyboard (but not in the matrix). The radio unit detects the depression of the power button and turns power on. When the button is pressed while power is on, the microcontroller of the handset detects it and sends a M2BUS message to the radio unit. The radio unit detects the duration of the key depression; if it is more than 0.5 seconds it will turn power off.

Oscillators

The clock frequency of 7.3728 MHz for the microcontroller is generated by crystal oscillator B4. In order to decrease harmonic frequencies resistor R2 and capacitor C32 are added.

The oscillator for the display driver and the negative five volt generator comprises inverter D3, resistors R33 and R34 and capacitor C47. The frequency is about 200 kHz.

Block Diagram of HSE-6XA

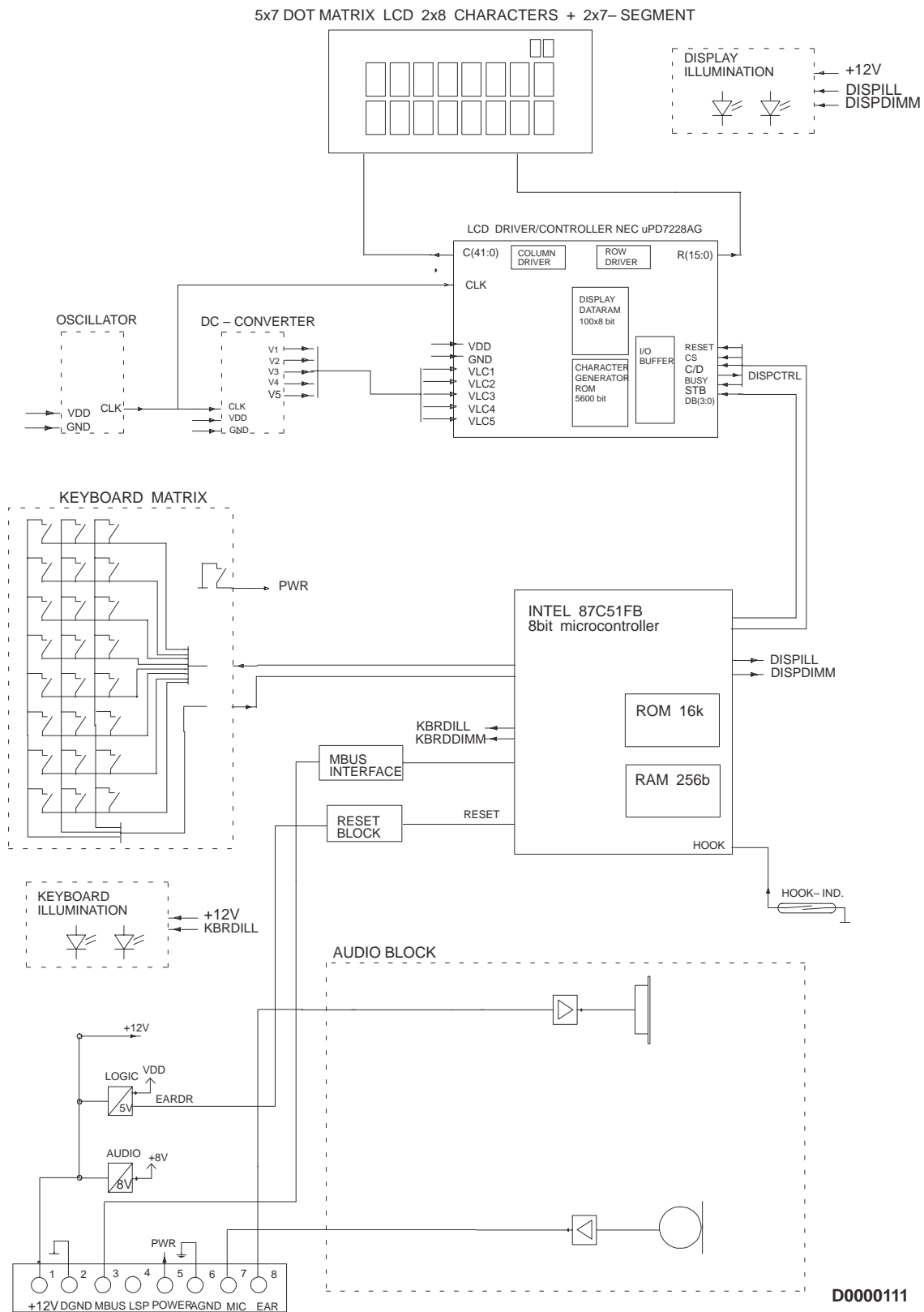

Figure 2. Block Diagram – HSE-6XA

Exploded View of HSE-6XA

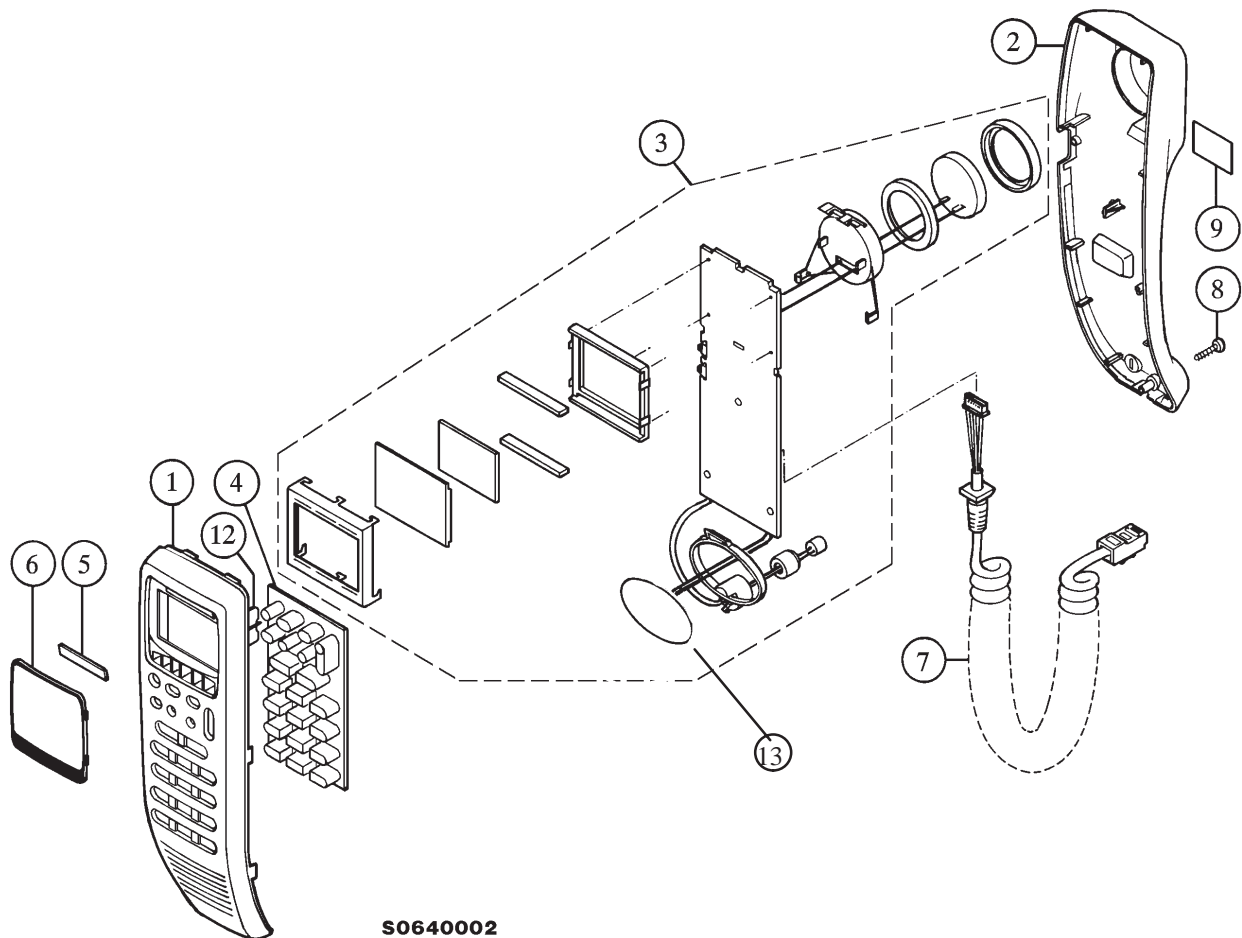

Figure 3. Exploded View HSE-6XA

Assembly Parts

ITEM	Q'TY	CODE	DESCRIPTION	VALUE, TYPE
1		9450015	Front cover	1D 21067
2		9450014	Bottom cover	1D 21068
3			Spare part combination	
4		9790169	Keypad HSE-6XA	DMC 00069
5		9204295	Logo plate "Nokia"	4D 21063
6		9457035	Display lens	4D 21151
7		7100410	Coil cord	3C 21414
8		6293003	PT-screw FeZn	KB 30x14 WN1442
9		9380154	Label Blank	
12		9450013	Volume button	2D 21137
13		9480329	Foam Piece	

Parts List of EH9 v.3.4

(EDMS Issue 3.4)

ITEM	CODE	DESCRIPTION	VALUE	TYPE
R001	1430087	Chip resistor	100 k	5 % 0.063 W 0603
R002	1430111	Chip resistor	1.0 M	5 % 0.063 W 0603
R003	1430087	Chip resistor	100 k	5 % 0.063 W 0603
R004	1430087	Chip resistor	100 k	5 % 0.063 W 0603
R006	1430075	Chip resistor	33 k	5 % 0.063 W 0603
R007	1430087	Chip resistor	100 k	5 % 0.063 W 0603
R008	1430067	Chip resistor	15 k	5 % 0.063 W 0603
R009	1430017	Chip resistor	390	5 % 0.063 W 0603
R010	1430067	Chip resistor	15 k	5 % 0.063 W 0603
R011	1430067	Chip resistor	15 k	5 % 0.063 W 0603
R012	1430035	Chip resistor	1.0 k	5 % 0.063 W 0603
R013	1430167	Chip resistor	47	5 % 0.063 W 0603
R015	1430065	Chip resistor	10 k	5 % 0.063 W 0603
R018	1430049	Chip resistor	3.9 k	5 % 0.063 W 0603
R019	1430049	Chip resistor	3.9 k	5 % 0.063 W 0603
R021	1430087	Chip resistor	100 k	5 % 0.063 W 0603
R022	1430035	Chip resistor	1.0 k	5 % 0.063 W 0603
R025	1430065	Chip resistor	10 k	5 % 0.063 W 0603
R026	1430065	Chip resistor	10 k	5 % 0.063 W 0603
R027	1430065	Chip resistor	10 k	5 % 0.063 W 0603
R028	1430065	Chip resistor	10 k	5 % 0.063 W 0603
R029	1430057	Chip resistor	8.2 k	5 % 0.063 W 0603
R030	1430049	Chip resistor	3.9 k	5 % 0.063 W 0603
R033	1430087	Chip resistor	100 k	5 % 0.063 W 0603
R034	1430065	Chip resistor	10 k	5 % 0.063 W 0603
R035	1430067	Chip resistor	15 k	5 % 0.063 W 0603
R036	1430067	Chip resistor	15 k	5 % 0.063 W 0603
R037	1430067	Chip resistor	15 k	5 % 0.063 W 0603
R038	1430067	Chip resistor	15 k	5 % 0.063 W 0603
R039	1430067	Chip resistor	15 k	5 % 0.063 W 0603
R040	1430065	Chip resistor	10 k	5 % 0.063 W 0603
R041	1800619	NTC resistor	15 k	10 % 1206
R042	1430049	Chip resistor	3.9 k	5 % 0.063 W 0603
R049	1430043	Chip resistor	2.2 k	5 % 0.063 W 0603
R060	1430067	Chip resistor	15 k	5 % 0.063 W 0603
R063	1430075	Chip resistor	33 k	5 % 0.063 W 0603
R067	1430067	Chip resistor	15 k	5 % 0.063 W 0603

R072	1430087	Chip resistor	100 k	5 % 0.063 W 0603
R073	1430075	Chip resistor	33 k	5 % 0.063 W 0603
R074	1430087	Chip resistor	100 k	5 % 0.063 W 0603
R075	1430087	Chip resistor	100 k	5 % 0.063 W 0603
R076	1430075	Chip resistor	33 k	5 % 0.063 W 0603
R077	1430075	Chip resistor	33 k	5 % 0.063 W 0603
R078	1430075	Chip resistor	33 k	5 % 0.063 W 0603
R079	1430065	Chip resistor	10 k	5 % 0.063 W 0603
R088	1430043	Chip resistor	2.2 k	5 % 0.063 W 0603
R104	1430057	Chip resistor	8.2 k	5 % 0.063 W 0603
R105	1430087	Chip resistor	100 k	5 % 0.063 W 0603
R107	1430065	Chip resistor	10 k	5 % 0.063 W 0603
R108	1430065	Chip resistor	10 k	5 % 0.063 W 0603
R109	1430065	Chip resistor	10 k	5 % 0.063 W 0603
R118	1430167	Chip resistor	47	5 % 0.063 W 0603
R120	1430167	Chip resistor	47	5 % 0.063 W 0603
R121	1430167	Chip resistor	47	5 % 0.063 W 0603
R122	1430167	Chip resistor	47	5 % 0.063 W 0603
R123	1430167	Chip resistor	47	5 % 0.063 W 0603
R124	1430151	Chip resistor	10	5 % 0.063 W 0603
R125	1430151	Chip resistor	10	5 % 0.063 W 0603
R128	1430065	Chip resistor	10 k	5 % 0.063 W 0603
R129	1430075	Chip resistor	33 k	5 % 0.063 W 0603
R130	1430065	Chip resistor	10 k	5 % 0.063 W 0603
R131	1430065	Chip resistor	10 k	5 % 0.063 W 0603
R132	1430065	Chip resistor	10 k	5 % 0.063 W 0603
R133	1430049	Chip resistor	3.9 k	5 % 0.063 W 0603
R134	1430035	Chip resistor	1.0 k	5 % 0.063 W 0603
R135	1430035	Chip resistor	1.0 k	5 % 0.063 W 0603
R136	1430035	Chip resistor	1.0 k	5 % 0.063 W 0603
R138	1430167	Chip resistor	47	5 % 0.063 W 0603
R139	1430035	Chip resistor	1.0 k	5 % 0.063 W 0603
R140	1430035	Chip resistor	1.0 k	5 % 0.063 W 0603
C007	2307816	Ceramic cap.	47 n	20 % 25 V 0805
C008	2610005	Tantalum cap.	10 u	20 % 16 V 3.5x2.8x1.9
C009	2604209	Tantalum cap.	1.0 u	20 % 16 V 3.2x1.6x1.6
C010	2610005	Tantalum cap.	10 u	20 % 16 V 3.5x2.8x1.9
C011	2320083	Ceramic cap.	1.0 n	5 % 50 V 0603
C012	2320107	Ceramic cap.	10 n	5 % 50 V 0603
C013	2610005	Tantalum cap.	10 u	20 % 16 V 3.5x2.8x1.9
C014	2320099	Ceramic cap.	4.7 n	5 % 50 V 0603
C015	2307816	Ceramic cap.	47 n	20 % 25 V 0805

C017	2307816	Ceramic cap.	47 n	20 % 25 V 0805
C018	2320107	Ceramic cap.	10 n	5 % 50 V 0603
C019	2307816	Ceramic cap.	47 n	20 % 25 V 0805
C022	2320045	Ceramic cap.	27 p	5 % 50 V 0603
C023	2320045	Ceramic cap.	27 p	5 % 50 V 0603
C024	2307816	Ceramic cap.	47 n	20 % 25 V 0805
C028	2610005	Tantalum cap.	10 u	20 % 16 V 3.5x2.8x1.9
C032	2320035	Ceramic cap.	10 p	5 % 50 V 0603
C033	2604209	Tantalum cap.	1.0 u	20 % 16 V 3.2x1.6x1.6
C034	2307816	Ceramic cap.	47 n	20 % 25 V 0805
C037	2610005	Tantalum cap.	10 u	20 % 16 V 3.5x2.8x1.9
C038	2320059	Ceramic cap.	100 p	5 % 50 V 0603
C039	2320107	Ceramic cap.	10 n	5 % 50 V 0603
C040	2320107	Ceramic cap.	10 n	5 % 50 V 0603
C041	2320107	Ceramic cap.	10 n	5 % 50 V 0603
C042	2320107	Ceramic cap.	10 n	5 % 50 V 0603
C043	2320059	Ceramic cap.	100 p	5 % 50 V 0603
C044	2320059	Ceramic cap.	100 p	5 % 50 V 0603
C045	2320059	Ceramic cap.	100 p	5 % 50 V 0603
C046	2320059	Ceramic cap.	100 p	5 % 50 V 0603
C047	2320059	Ceramic cap.	100 p	5 % 50 V 0603
C048	2320059	Ceramic cap.	100 p	5 % 50 V 0603
C049	2320059	Ceramic cap.	100 p	5 % 50 V 0603
C050	2320059	Ceramic cap.	100 p	5 % 50 V 0603
C051	2320059	Ceramic cap.	100 p	5 % 50 V 0603
C052	2320059	Ceramic cap.	100 p	5 % 50 V 0603
C053	2320059	Ceramic cap.	100 p	5 % 50 V 0603
C054	2320059	Ceramic cap.	100 p	5 % 50 V 0603
C055	2320059	Ceramic cap.	100 p	5 % 50 V 0603
C056	2310752	Ceramic cap.	10 n	20 % 50 V 0805
C057	2307816	Ceramic cap.	47 n	20 % 25 V 0805
C058	2307816	Ceramic cap.	47 n	20 % 25 V 0805
C059	2307816	Ceramic cap.	47 n	20 % 25 V 0805
C060	2307816	Ceramic cap.	47 n	20 % 25 V 0805
C061	2604209	Tantalum cap.	1.0 u	20 % 16 V 3.2x1.6x1.6
C062	2604209	Tantalum cap.	1.0 u	20 % 16 V 3.2x1.6x1.6
C063	2320059	Ceramic cap.	100 p	5 % 50 V 0603
C064	2320099	Ceramic cap.	4.7 n	5 % 50 V 0603
C065	2610005	Tantalum cap.	10 u	20 % 16 V 3.5x2.8x1.9
B004	4510036	Crystal	7.3728 M	+/-50PPM 12x6x3mm
V001	4864378	Led	Green	V 0805
V002	4864378	Led	Green	V 0805

V003	4864378	Led	Green	V 0805	
V004	4864378	Led	Green	V 0805	
V005	4864378	Led	Green	V 0805	
V006	4864378	Led	Green	V 0805	
V007	4864378	Led	Green	V 0805	
V008	4864378	Led	Green	V 0805	
V009	4864378	Led	Green	V 0805	
V010	4864378	Led	Green	V 0805	
V011	4864378	Led	Green	V 0805	
V012	4864378	Led	Green	V 0805	
V013	4864378	Led	Green	V 0805	
V014	4864378	Led	Green	V 0805	
V015	4200917	Transistor	BC848B/BCW32	npn 30 V 100 mA	SOT23
V026	4200917	Transistor	BC848B/BCW32	npn 30 V 100 mA	SOT23
V027	4200917	Transistor	BC848B/BCW32	npn 30 V 100 mA	SOT23
V028	4200917	Transistor	BC848B/BCW32	npn 30 V 100 mA	SOT23
V029	4108639	Diode x 2	BAS28	75 V 250 mA	SOT143
V032	4108639	Diode x 2	BAS28	75 V 250 mA	SOT143
V033	4108639	Diode x 2	BAS28	75 V 250 mA	SOT143
V034	4200917	Transistor	BC848B/BCW32	npn 30 V 100 mA	SOT23
V035	4200917	Transistor	BC848B/BCW32	npn 30 V 100 mA	SOT23
V036	4108639	Diode x 2	BAS28	75 V 250 mA	SOT143
V037	4200917	Transistor	BC848B/BCW32	npn 30 V 100 mA	SOT23
V038	4108639	Diode x 2	BAS28	75 V 250 mA	SOT143
V039	4200917	Transistor	BC848B/BCW32	npn 30 V 100 mA	SOT23
V040	4200917	Transistor	BC848B/BCW32	npn 30 V 100 mA	SOT23
V041	4200917	Transistor	BC848B/BCW32	npn 30 V 100 mA	SOT23
V042	4200917	Transistor	BC848B/BCW32	npn 30 V 100 mA	SOT23
V043	4864378	Led	Green	V 0805	
V044	4864378	Led	Green	V 0805	
V045	4864378	Led	Green	V 0805	
V046	4864378	Led	Green	V 0805	
V047	4864378	Led	Green	V 0805	
V048	4864378	Led	Green	V 0805	
V049	4864378	Led	Green	V 0805	
V050	4864378	Led	Green	V 0805	
V051	4864378	Led	Green	V 0805	
V052	4864378	Led	Green	V 0805	
V053	4864378	Led	Green	V 0805	
V054	4864378	Led	Green	V 0805	
V055	4864378	Led	Green	V 0805	
V056	4864378	Led	Green	V 0805	

D001	0240427	MCU Software Module		
	4370157	MCU 8BIT5V OTP16K RAM256X8 PLCC44		
	8400472	ROM Code		
	9380149	Sticker Brady LAT-2-747 9.5X9.5		
D002	4309047	IC, LCD driver	uPD7228 QFP80	
D003	4309569	IC, 6 x inverter	4069 SO14	
N003	4306494	IC, 2 x op.amp.	TL074ID SO14	
N004	4301062	IC, regulator	LP2951AC	SO8S
N005	4301062	IC, regulator	LP2951AC	SO8S
S022	5200116	Bush button switch 1-lock 1-pole		1-POLE
S023	5200116	Bush button switch 1-lock 1-pole		1-POLE
S025	5304759	Reed relay 10at 0.5a 2x15 smd		
X001	5416638	Connector 8-pole right angle 1.5		1.5
X002	5416640	Pin header m1x2 p1.5 90deg 1a0r02		1A0R02
X003	5416640	Pin header m1x2 p1.5 90deg 1a0r02		1A0R02
X004	5416640	Pin header m1x2 p1.5 90deg 1a0r02		1A0R02
A001	9510038	RF shield	3D21421 HSE-1	
P001	9854152	PC board EH9	135.9x48.0x1.6 m4 3/pa	
	5140450	Cond. microphone 62+-		2DB HSE-1
	5140566	Receiver capsule cr-4e with leads		LEADS
	9854152	PCB EH9 135.9X48.0X1.6 M4 3/PA		

Parts List of EH9 v.4.1

(0200905 EDMS Issue 4.1)

ITEM	CODE	DESCRIPTION	VALUE	TYPE
R001	1430087	Chip resistor	100 k	5 % 0.063 W 0603
R002	1430111	Chip resistor	1.0 M	5 % 0.063 W 0603
R003	1430087	Chip resistor	100 k	5 % 0.063 W 0603
R004	1430087	Chip resistor	100 k	5 % 0.063 W 0603
R006	1430075	Chip resistor	33 k	5 % 0.063 W 0603
R007	1430087	Chip resistor	100 k	5 % 0.063 W 0603
R008	1430067	Chip resistor	15 k	5 % 0.063 W 0603
R009	1430017	Chip resistor	390	5 % 0.063 W 0603
R010	1430067	Chip resistor	15 k	5 % 0.063 W 0603
R011	1430067	Chip resistor	15 k	5 % 0.063 W 0603
R012	1430035	Chip resistor	1.0 k	5 % 0.063 W 0603
R013	1430167	Chip resistor	47	5 % 0.063 W 0603
R014	1430001	Chip resistor	100	5 % 0.063 W 0603
R015	1430065	Chip resistor	10 k	5 % 0.063 W 0603
R016	1430007	Chip resistor	180	5 % 0.063 W 0603
R017	1430007	Chip resistor	180	5 % 0.063 W 0603
R018	1430049	Chip resistor	3.9 k	5 % 0.063 W 0603
R019	1430049	Chip resistor	3.9 k	5 % 0.063 W 0603
R021	1430087	Chip resistor	100 k	5 % 0.063 W 0603
R022	1430035	Chip resistor	1.0 k	5 % 0.063 W 0603
R023	1430001	Chip resistor	100	5 % 0.063 W 0603
R025	1430065	Chip resistor	10 k	5 % 0.063 W 0603
R026	1430065	Chip resistor	10 k	5 % 0.063 W 0603
R027	1430065	Chip resistor	10 k	5 % 0.063 W 0603
R028	1430065	Chip resistor	10 k	5 % 0.063 W 0603
R029	1430057	Chip resistor	8.2 k	5 % 0.063 W 0603
R030	1430049	Chip resistor	3.9 k	5 % 0.063 W 0603
R033	1430087	Chip resistor	100 k	5 % 0.063 W 0603
R034	1430065	Chip resistor	10 k	5 % 0.063 W 0603
R035	1430067	Chip resistor	15 k	5 % 0.063 W 0603
R036	1430067	Chip resistor	15 k	5 % 0.063 W 0603
R037	1430067	Chip resistor	15 k	5 % 0.063 W 0603
R038	1430067	Chip resistor	15 k	5 % 0.063 W 0603
R039	1430067	Chip resistor	15 k	5 % 0.063 W 0603
R040	1430065	Chip resistor	10 k	5 % 0.063 W 0603
R041	1800619	NTC resistor	15 k	10 % 1206
R042	1430049	Chip resistor	3.9 k	5 % 0.063 W 0603
R049	1430043	Chip resistor	2.2 k	5 % 0.063 W 0603
R060	1430067	Chip resistor	15 k	5 % 0.063 W 0603
R063	1430075	Chip resistor	33 k	5 % 0.063 W 0603
R067	1430067	Chip resistor	15 k	5 % 0.063 W 0603
R071	1430001	Chip resistor	100	5 % 0.063 W 0603

R072	1430087	Chip resistor	100 k	5 % 0.063 W 0603
R073	1430075	Chip resistor	33 k	5 % 0.063 W 0603
R074	1430087	Chip resistor	100 k	5 % 0.063 W 0603
R075	1430087	Chip resistor	100 k	5 % 0.063 W 0603
R076	1430075	Chip resistor	33 k	5 % 0.063 W 0603
R077	1430075	Chip resistor	33 k	5 % 0.063 W 0603
R078	1430075	Chip resistor	33 k	5 % 0.063 W 0603
R079	1430065	Chip resistor	10 k	5 % 0.063 W 0603
R081	1430007	Chip resistor	180	5 % 0.063 W 0603
R082	1430007	Chip resistor	180	5 % 0.063 W 0603
R083	1430007	Chip resistor	180	5 % 0.063 W 0603
R084	1430007	Chip resistor	180	5 % 0.063 W 0603
R088	1430043	Chip resistor	2.2 k	5 % 0.063 W 0603
R103	1430001	Chip resistor	100	5 % 0.063 W 0603
R104	1430057	Chip resistor	8.2 k	5 % 0.063 W 0603
R105	1430087	Chip resistor	100 k	5 % 0.063 W 0603
R107	1430065	Chip resistor	10 k	5 % 0.063 W 0603
R108	1430065	Chip resistor	10 k	5 % 0.063 W 0603
R109	1430065	Chip resistor	10 k	5 % 0.063 W 0603
R118	1430167	Chip resistor	47	5 % 0.063 W 0603
R119	1430007	Chip resistor	180	5 % 0.063 W 0603
R120	1430167	Chip resistor	47	5 % 0.063 W 0603
R121	1430167	Chip resistor	47	5 % 0.063 W 0603
R122	1430167	Chip resistor	47	5 % 0.063 W 0603
R123	1430167	Chip resistor	47	5 % 0.063 W 0603
R124	1430151	Chip resistor	10	5 % 0.1 W 0603
R125	1430151	Chip resistor	10	5 % 0.1 W 0603
R128	1430065	Chip resistor	10 k	5 % 0.063 W 0603
R129	1430075	Chip resistor	33 k	5 % 0.063 W 0603
R130	1430065	Chip resistor	10 k	5 % 0.063 W 0603
R131	1430065	Chip resistor	10 k	5 % 0.063 W 0603
R132	1430065	Chip resistor	10 k	5 % 0.063 W 0603
R133	1430049	Chip resistor	3.9 k	5 % 0.063 W 0603
R134	1430035	Chip resistor	1.0 k	5 % 0.063 W 0603
R135	1430035	Chip resistor	1.0 k	5 % 0.063 W 0603
R136	1430035	Chip resistor	1.0 k	5 % 0.063 W 0603
R137	1430001	Chip resistor	100	5 % 0.063 W 0603
R138	1430167	Chip resistor	47	5 % 0.063 W 0603
R139	1430035	Chip resistor	1.0 k	5 % 0.063 W 0603
R140	1430035	Chip resistor	1.0 k	5 % 0.063 W 0603
C007	2307816	Ceramic cap.	47 n	20 % 25 V 0805
C008	2610005	Tantalum cap. 3.5x2.8x1.9	10 u	20 % 16 V
C009	2604209	Tantalum cap. 3.2x1.6x1.6	1.0 u	20 % 16 V
C010	2610005	Tantalum cap. 3.5x2.8x1.9	10 u	20 % 16 V

Handset HSE - 6XA

Technical Documentation

C011	2320083	Ceramic cap.	1.0 n	5 % 50 V 0603
C012	2320107	Ceramic cap.	10 n	5 % 50 V 0603
C013	2610005	Tantalum cap. 3.5x2.8x1.9	10 u	20 % 16 V
C014	2320099	Ceramic cap.	4.7 n	5 % 50 V 0603
C015	2307816	Ceramic cap.	47 n	20 % 25 V 0805
C017	2307816	Ceramic cap.	47 n	20 % 25 V 0805
C018	2320107	Ceramic cap.	10 n	5 % 50 V 0603
C019	2307816	Ceramic cap.	47 n	20 % 25 V 0805
C022	2320045	Ceramic cap.	27 p	5 % 50 V 0603
C023	2320045	Ceramic cap.	27 p	5 % 50 V 0603
C024	2307816	Ceramic cap.	47 n	20 % 25 V 0805
C028	2610005	Tantalum cap. 3.5x2.8x1.9	10 u	20 % 16 V
C032	2320035	Ceramic cap.	10 p	5 % 50 V 0603
C033	2604209	Tantalum cap. 3.2x1.6x1.6	1.0 u	20 % 16 V
C034	2307816	Ceramic cap.	47 n	20 % 25 V 0805
C037	2610005	Tantalum cap. 3.5x2.8x1.9	10 u	20 % 16 V
C038	2320059	Ceramic cap.	100 p	5 % 50 V 0603
C039	2320107	Ceramic cap.	10 n	5 % 50 V 0603
C040	2320107	Ceramic cap.	10 n	5 % 50 V 0603
C041	2320107	Ceramic cap.	10 n	5 % 50 V 0603
C042	2320107	Ceramic cap.	10 n	5 % 50 V 0603
C043	2320059	Ceramic cap.	100 p	5 % 50 V 0603
C044	2320059	Ceramic cap.	100 p	5 % 50 V 0603
C045	2320059	Ceramic cap.	100 p	5 % 50 V 0603
C046	2320059	Ceramic cap.	100 p	5 % 50 V 0603
C047	2320059	Ceramic cap.	100 p	5 % 50 V 0603
C048	2320059	Ceramic cap.	100 p	5 % 50 V 0603
C049	2320059	Ceramic cap.	100 p	5 % 50 V 0603
C050	2320059	Ceramic cap.	100 p	5 % 50 V 0603
C051	2320059	Ceramic cap.	100 p	5 % 50 V 0603
C052	2320059	Ceramic cap.	100 p	5 % 50 V 0603
C053	2320059	Ceramic cap.	100 p	5 % 50 V 0603
C054	2320059	Ceramic cap.	100 p	5 % 50 V 0603
C055	2320059	Ceramic cap.	100 p	5 % 50 V 0603
C056	2310752	Ceramic cap.	10 n	20 % 50 V 0805
C057	2307816	Ceramic cap.	47 n	20 % 25 V 0805
C058	2307816	Ceramic cap.	47 n	20 % 25 V 0805
C059	2307816	Ceramic cap.	47 n	20 % 25 V 0805
C060	2307816	Ceramic cap.	47 n	20 % 25 V 0805
C061	2604209	Tantalum cap. 3.2x1.6x1.6	1.0 u	20 % 16 V
C062	2604209	Tantalum cap. 3.2x1.6x1.6	1.0 u	20 % 16 V

Technical Documentation

Handset HSE - 6XA

C063	2320059	Ceramic cap.	100 p	5 % 50 V 0603
C064	2320099	Ceramic cap.	4.7 n	5 % 50 V 0603
C065	2610005	Tantalum cap.	10 u	20 % 16 V
3.5x2.8x1.9				
B004	4510036	Crystal	7.3728 M	+−50PPM 12x6x3mm
V001	4864378	Led	Green	V 0805
V002	4864378	Led	Green	V 0805
V003	4864378	Led	Green	V 0805
V004	4864378	Led	Green	V 0805
V005	4864378	Led	Green	V 0805
V006	4864378	Led	Green	V 0805
V007	4864378	Led	Green	V 0805
V008	4864378	Led	Green	V 0805
V009	4864378	Led	Green	V 0805
V010	4864378	Led	Green	V 0805
V011	4864378	Led	Green	V 0805
V012	4864378	Led	Green	V 0805
V013	4864378	Led	Green	V 0805
V014	4864378	Led	Green	V 0805
V015	4200917	Transistor	BC848B/BCW32	npn 30 V 100 mA
SOT23				
V026	4200917	Transistor	BC848B/BCW32	npn 30 V 100 mA
SOT23				
V027	4200917	Transistor	BC848B/BCW32	npn 30 V 100 mA
SOT23				
V028	4200917	Transistor	BC848B/BCW32	npn 30 V 100 mA
SOT23				
V029	4108639	Diode x 2	BAS28	75 V 250 mA
SOT143				
V032	4108639	Diode x 2	BAS28	75 V 250 mA
SOT143				
V033	4108639	Diode x 2	BAS28	75 V 250 mA
SOT143				
V034	4200917	Transistor	BC848B/BCW32	npn 30 V 100 mA
SOT23				
V035	4200917	Transistor	BC848B/BCW32	npn 30 V 100 mA
SOT23				
V036	4108639	Diode x 2	BAS28	75 V 250 mA
SOT143				
V037	4200917	Transistor	BC848B/BCW32	npn 30 V 100 mA
SOT23				
V038	4108639	Diode x 2	BAS28	75 V 250 mA
SOT143				
V039	4200917	Transistor	BC848B/BCW32	npn 30 V 100 mA
SOT23				
V040	4200917	Transistor	BC848B/BCW32	npn 30 V 100 mA
SOT23				

V041	4200917	Transistor	BC848B/BCW32	npn30V100mSOT23
V042	4200917	Transistor	BC848B/BCW32	npn30V100mSOT23
V043	4864378	Led	Green	V 0805
V044	4864378	Led	Green	V 0805
V045	4864378	Led	Green	V 0805
V046	4864378	Led	Green	V 0805
V047	4864378	Led	Green	V 0805
V048	4864378	Led	Green	V 0805
V049	4864378	Led	Green	V 0805
V050	4864378	Led	Green	V 0805
V051	4864378	Led	Green	V 0805
V052	4864378	Led	Green	V 0805
V053	4864378	Led	Green	V 0805
V054	4864378	Led	Green	V 0805
V055	4864378	Led	Green	V 0805
V056	4864378	Led	Green	V 0805
D001	4370437	IC, MCU		PLCC44
D002	4309047	IC, LCD driver	uPD7228	QFP80
D003	4309569	IC, 6 x inverter	4069	SO14
N003	4306494	IC, 2 x op.amp.	TL074ID	SO14
N004	4301062	IC, regulator	LP2951AC	SO8S
N005	4301062	IC, regulator	LP2951AC	SO8S
S022	5200116	Bush button switch 1-lock		1-POLE
S023	5200116	Bush button switch 1-lock		1-POLE
S025	5304759	Reed relay 10at 0.5a 2x15		smd
X001	5416638	Connector 8-pole right angle		1.5
X002	5416640	Pin header m1x2 p1.5 90deg 1a0r02		1A0R02
X003	5416640	Pin header m1x2 p1.5 90deg 1a0r02		1A0R02
A001	9510038	RF shield	3D21421	HSE-1
P001	9854152	PC board EH9	135.9x48.0x1.6	m4 3/pa